



# High-Slope, Low-Power, Analog Temperature Sensor in an SC70 Package

MAX6612

## General Description

The MAX6612 is a low-power precision analog output temperature sensor in a tiny 5-pin SC70 package. The sensitivity of the output voltage to temperature is a high 19.53mV/°C. This sensitivity provides superior noise immunity. The voltage/temperature slope is chosen to provide convenient bit weights when the MAX6612 drives the input of an ADC with a 2.5V or 5V reference.

The MAX6612 provides an analog voltage output proportional to temperature. Accuracy is  $\pm 1.2^\circ\text{C}$  (max) at  $+25^\circ\text{C}$ ,  $\pm 3.0$  (max) from  $T_A = 0^\circ\text{C}$  to  $+70^\circ\text{C}$ , and  $\pm 5.5^\circ\text{C}$  (max) from  $T_A = -10^\circ\text{C}$  to  $+125^\circ\text{C}$ . Useful measurements can be obtained at temperatures as high as  $+150^\circ\text{C}$ . Self-heating effects are negligible due to the low current consumption of the part.

Unlike many analog temperature sensors, the MAX6612 is stable with large capacitive loads. Any capacitive load greater than or equal to 1000pF yields stable operation, providing broad flexibility in board-level design.

The operating temperature range varies with the supply voltage, with a higher supply voltage enabling a wider temperature range. The MAX6612 can be used over a range of  $-10^\circ\text{C}$  to  $+125^\circ\text{C}$  with a supply voltage of 3.3V or greater. For applications with a supply voltage of 2.4V, the MAX6612 can be used over a temperature range of  $-10^\circ\text{C}$  to  $+70^\circ\text{C}$ .

## Applications

- Base Stations
- Industrial Equipment
- Home Appliances
- Battery Packs
- Medical Instruments
- Portable Equipment
- GPS Equipment

## Features

- ◆ Optimized for Use with ADCs
- ◆ High Temperature-to-Voltage Slope
- ◆ Able to Drive High-Capacitive Loads
- ◆ Operates Up to  $+150^\circ\text{C}$
- ◆ Low Current Consumption (35 $\mu\text{A}$  max)
- ◆ No Calibration Required
- ◆ Space-Saving SC70 Package

## Ordering Information

PART	TEMP RANGE	PIN-PACKAGE	TOP MARK
MAX6612MXK-T	$-55^\circ\text{C}$ to $+150^\circ\text{C}$	5 SC70-5	ADG

## Pin Configuration

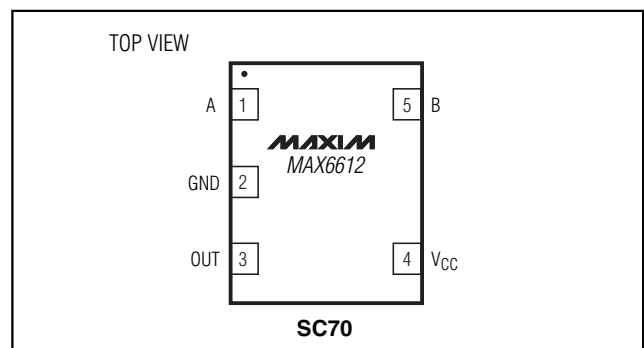

## Typical Application Circuit

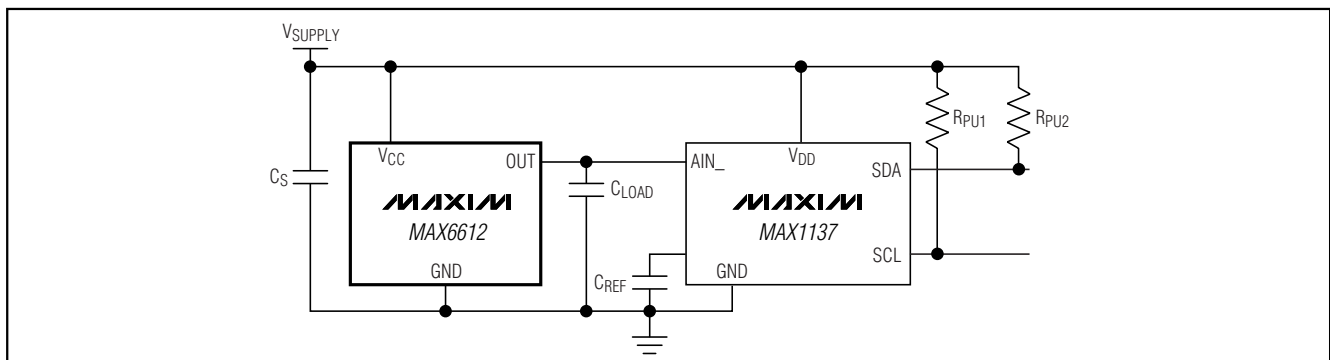

# High-Slope, Low-Power, Analog Temperature Sensor in an SC70 Package

## ABSOLUTE MAXIMUM RATINGS

V <sub>CC</sub> to GND .....	-0.3V to +6V
OUT to GND.....	-0.3V to V <sub>CC</sub> + 0.3V
ESD Protection (Human Body).....	2000V
Current into Any Pin .....	20mA
Output Short-Circuit Duration.....	Continuous

Continuous Power Dissipation (T <sub>A</sub> = +70°C)	
5-Pin SC70 (derate 3.1mW/°C above +70°C).....	245mW
Operating Temperature Range .....	-55°C to +150°C
Junction Temperature .....	+150°C
Storage Temperature Range .....	-65°C to +165°C
Lead Temperature (soldering, 10s).....	+300°C

Stresses beyond those listed under "Absolute Maximum Ratings" may cause permanent damage to the device. These are stress ratings only, and functional operation of the device at these or any other conditions beyond those indicated in the operational sections of the specifications is not implied. Exposure to absolute maximum rating conditions for extended periods may affect device reliability.

## ELECTRICAL CHARACTERISTICS

(V<sub>CC</sub> = 2.4V to 5.5V, C<sub>LOAD</sub> = 1000pF, T<sub>A</sub> = -10°C to +150°C, unless otherwise specified.)

PARAMETER	SYMBOL	CONDITIONS	MIN	TYP	MAX	UNITS
Temperature Error V <sub>OUT</sub> = 0.4 + (0.01953 × T) – (2 × 10 <sup>-6</sup> × T <sup>2</sup> ) (Notes 1, 2)		T <sub>A</sub> = +25°C, V <sub>CC</sub> = 3.3V	-1.2		+1.2	°C
		T <sub>A</sub> = +60°C to +70°C, V <sub>CC</sub> = 3.3V	-3.0		+3.0	
		T <sub>A</sub> = +60°C to +100°C, V <sub>CC</sub> = 3.3V	-4.3		+4.3	
		T <sub>A</sub> = -10°C to +125°C, V <sub>CC</sub> = 3.3V	-5.5		+5.5	
		T <sub>A</sub> = -10°C to +150°C, V <sub>CC</sub> = 5.5V		±5		
Supply Voltage Range	V <sub>CC</sub>		2.4	2.3	5.5	V
Supply Current	I <sub>Q</sub>	No load			35	μA
Output Voltage	V <sub>OUT</sub>	T <sub>A</sub> = 0°C		400		mV
Sensor Gain (Average Slope)		T <sub>A</sub> = -10°C to +150°C		19.53		mV/°C
Capacitive Load		No sustained oscillations (Note 3)	1000			pF
Turn-On Time		C <sub>LOAD</sub> = 1000pF		80		μs
Shutdown Current		V <sub>CC</sub> < 0.8V		1		μA
Supply Sensitivity		V <sub>CC</sub> = 2.4V to 5.5V		0.5	0.8	°C/V
Load Regulation		I <sub>OUT</sub> = 2μA to 100μA		0.03		°C/μA

**Note 1:** 100% production tested at +25°C. Guaranteed by design through temperature.

**Note 2:** T is in °C.

**Note 3:** Guaranteed by design.

## Typical Operating Characteristics

(V<sub>CC</sub> = 3.3V, C<sub>S</sub> = 0.1μF, C<sub>LOAD</sub> = 1000pF, unless otherwise specified.)

**OUTPUT VOLTAGE vs. AMBIENT TEMPERATURE**

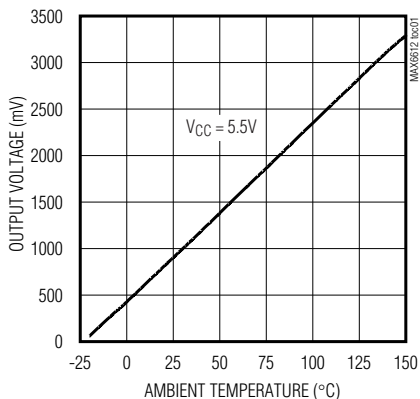

**SUPPLY CURRENT vs. SUPPLY VOLTAGE**

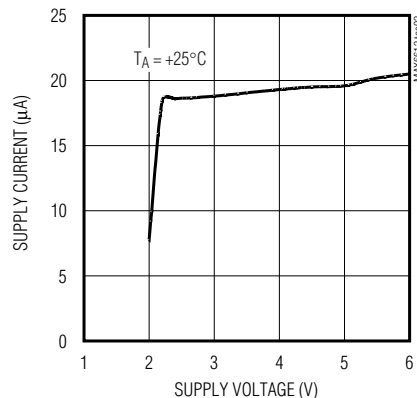

# High-Slope, Low-Power, Analog Temperature Sensor in an SC70 Package

MAX6612

## Typical Operating Characteristics (continued)

( $V_{CC} = 3.3V$ ,  $C_S = 0.1\mu F$ ,  $C_{LOAD} = 1000pF$ , unless otherwise specified.)

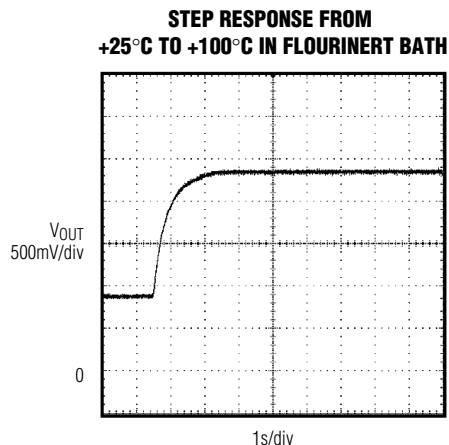
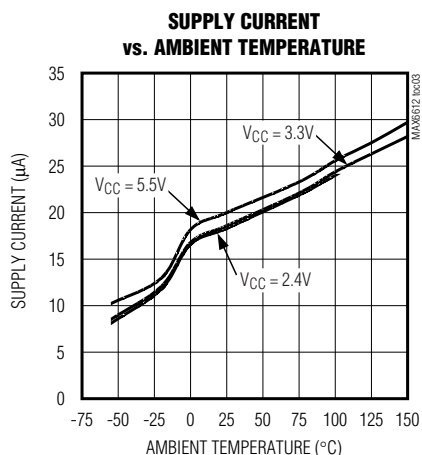

### Pin Description

PIN	NAME	FUNCTION
1	A	Must be connected to GND.
2	GND	GND
3	OUT	Temperature Sensor Output. Connect a capacitor (at least 1000pF) from this pin to GND.
4	$V_{CC}$	Power-Supply Input. Bypass $V_{CC}$ to GND with a 0.1μF ceramic capacitor.
5	B	Must be connected to GND.

### Detailed Description

The MAX6612 is an analog output temperature sensor whose output voltage is a linear function of its die temperature. The slope of the output voltage is 19.53mV/°C and there is a 400mV offset at 0°C to allow measurement of negative temperatures. The maximum supply current is 35μA, and the supply voltage range is from 2.4V to 5.5V for the -10°C to +150°C temperature range. The temperature error is less than ±1.2°C at  $T_A = +25°C$ , ±3°C from  $T_A = 0°C$  to +70°C, and ±4.5°C from  $T_A = -10°C$  to +125°C.

The operating temperature range varies with the supply voltage with higher supply voltages enabling wider temperature ranges. The MAX6612 can be used over a range of -10°C to +125°C with a supply voltage of 3.3V or greater. For applications with a supply voltage of 2.4V, the MAX6612 can be used over a temperature range of -10°C to +70°C.

### Transfer Function

The temperature-to-voltage transfer function has a linear positive slope and can be approximated by the equation:

$$V_{OUT} = 0.40V + (0.01953V/°C \times T°C) - (2 \times 10^{-6} \times T°C^2)$$

where T is the MAX6612's die temperature in °C.

Therefore:

$$T (°C) = (V_{OUT} - 0.40V) / 0.01953V/°C$$

### Applications Information

#### Sensing Circuit Board and Ambient Temperatures

Temperature sensor ICs like the MAX6612 that sense their own die temperatures must be mounted on or close to the object whose temperature they are intended to measure. Because there is a good thermal path between the SC70 package's metal leads and the IC die, the MAX6612 can accurately measure the temperature of the circuit board to which it is soldered. If the sensor is intended to measure the temperature of a heat-generating component on the circuit board, it should be mounted as close as possible to that component and should share supply and ground traces (if they are not noisy) with that component where possible. This maximizes the heat transfer from the component to the sensor.

## High-Slope, Low-Power, Analog Temperature Sensor in an SC70 Package

The thermal path between the plastic package and the die is not as good as the path through the leads, so the MAX6612, like all temperature sensors in plastic packages, is less sensitive to the temperature of the surrounding air than it is to the temperature of its leads. It can be successfully used to sense ambient temperature if the circuit board is designed to track the ambient temperature.

As with any IC, the wiring and circuits must be kept insulated and dry to avoid leakage and corrosion, especially if the part is operated at cold temperatures where condensation can occur.

The MAX6612 is a very low-power temperature sensor and is intended to drive very light loads. As a result, the temperature rise due to power dissipation on the die is insignificant under normal conditions. For example, with the MAX6612 operating from a 3V supply at +25°C ( $V_{OUT} = 0.888V$ ), driving a 100k $\Omega$  load ( $I_{OUT} = 10\mu A$ ), and in the 5-pin SC70 package, the die temperature increases above the ambient by 0.036°C. Therefore, the error caused by power dissipation is negligible.

### Driving ADC Inputs

The MAX6612's temperature-to-voltage transfer function provides convenient LSB weights when driving ADCs with 2.5V or 5V references. With a 5V reference, an 8-bit ADC has an LSB value equal to 19.53mV, which corresponds exactly to the voltage produced by a 1°C change in the MAX6612's temperature. An 8-bit ADC with a 2.5V reference has an LSB value of 9.765mV, or 0.5°C.

### Capacitive Loads

The MAX6612 is optimized for stability with large capacitive loads such as noise-filtering capacitors at the input of an ADC. For stable operation, ensure that the MAX6612 has a load capacitance of at least 1000pF located near its output pin.

### Chip Information

TRANSISTOR COUNT: 257

PROCESS: BiCMOS

# High-Slope, Low-Power, Analog Temperature Sensor in an SC70 Package

## Package Information

(The package drawing(s) in this data sheet may not reflect the most current specifications. For the latest package outline information, go to [www.maxim-ic.com/packages](http://www.maxim-ic.com/packages).)

**MAX6612**

SC70, 5LEPS

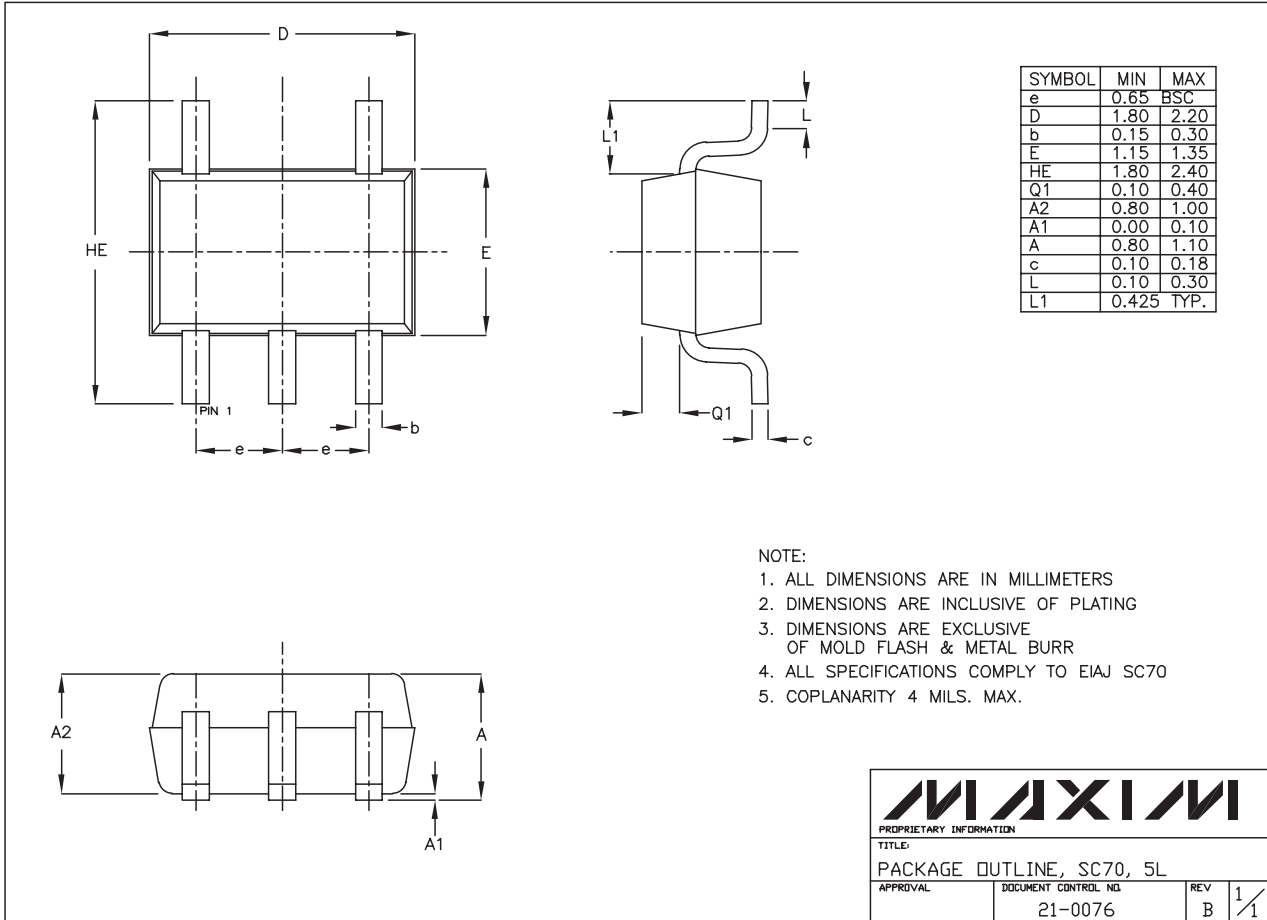

Maxim cannot assume responsibility for use of any circuitry other than circuitry entirely embodied in a Maxim product. No circuit patent licenses are implied. Maxim reserves the right to change the circuitry and specifications without notice at any time.

**Maxim Integrated Products, 120 San Gabriel Drive, Sunnyvale, CA 94086 408-737-7600** \_\_\_\_\_ 5